



4000-BP

INSTALLATION • INSTRUCTIONS • SERVICE GUIDE



CAUTION! Read through this entire booklet before placing your Alpha Backpack 4000-BP into service. Improper use may damage your backpack and void the warranty. You may also expose yourself to unnecessary danger and/or physical injury.

Assembly & Operating Instructions

1. Remove the poly backpack from all packaging.

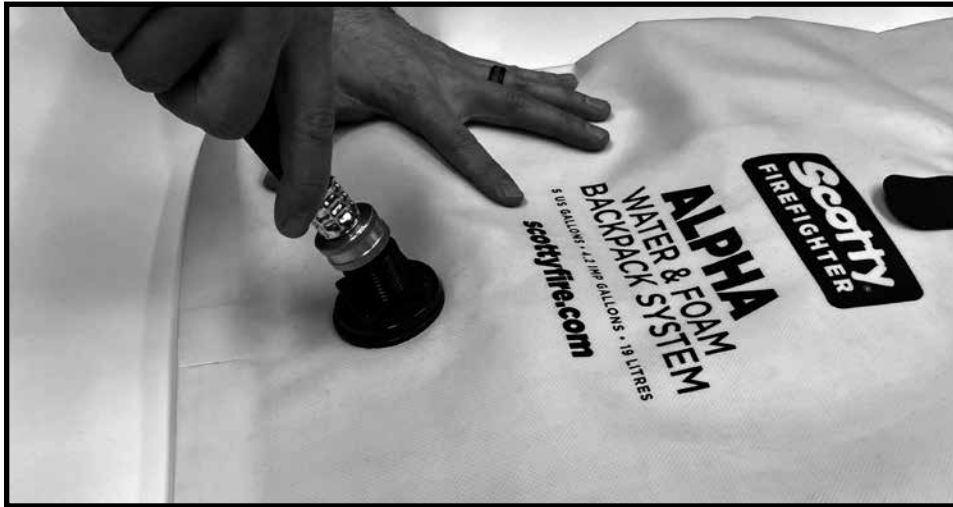

2. Connect the female end of the suction hose to the $\frac{3}{4}$ " male fitting located at the bottom of the backpack.



3. Ensure that the quick connect shut-off on the 4' long pick-up hose is in the off (closed) position.
4. Connect the quick connect fitting of the suction hose to the male quick connect nipple of the hand pump. This is located below the check valve tee on the water hand pump.



5. Remove the 4" fill cap by turning the cap counter-clockwise and fill the backpack with water. The capacity is 5 gallons/19 litres.



6. The filter screen can be removed to aid with filling. To level the fill opening, pull the tabs located on the front and back of the backpack. (alternatively, the backpack can also be filled by laying it in a shallow creek or at a lakeshore and open the fill cap while submerged.)
7. Once you have filled the backpack, re-install the fill cap. Please ensure that the filter screen and retaining ring are still in place.
8. Turn the quick connect valve to the on position. (open)
9. Point nozzle at the area to be sprayed. Pull back on the pump handle until it stops and push it forward (like a bicycle pump). Repeated pumping action will draw water from the backpack through the suction hose to refill the pump.
10. Adjust (twist) the nozzle to desired spray pattern.

Maintenance & Service

BACKPACK MAINTENANCE

1. Open fill cap and clean or remove any dirt/debris from the filter screen.
2. After each use or before storage rinse backpack with clean water.
3. Inspect the fill cap and gasket. If any signs of damage, replace as required.
4. For dry storage, do not reinstall cap and store backpack upside down.

HAND PUMP MAINTENANCE

1. After use or before storage, pump clean water through the hand pump.
2. Periodically, apply a small amount of lubricating oil or grease to the piston rod and piston O-ring.
3. Twist spray nozzle to ensure smooth operation, if any resistance is found completely untwist the nozzle body and apply a small amount of lubricating oil or grease to the O-ring.
4. Inspect suction hose for cracks, burns or leaks. Replace the hose if needed.
5. For dry storage, remove suction hose and operate pump until dry.

HAND PUMP CHECK VALVE SERVICE/REPLACEMENT

1. Disassemble the hand pump by unscrewing the connector nut at the handle end of the pump chamber.
2. Remove the piston rod by gently pulling the pump handle until it separates from the pump chamber.
3. Cut or pry off the old O-ring on the piston. Replace O-ring.
4. Unscrew the cartridge valve sleeve from the pump. Remove and discard the old cartridge valve. Do not discard the $\frac{3}{4}$ " gasket.
5. Replace with a new cartridge valve. Be sure to install the new cartridge valve according to the diagram below. The valve must be positioned the correct way to function properly. Reinstall the $\frac{3}{4}$ " gasket and screw the cartridge valve sleeve back onto the pump.
6. Unscrew the quick connect insert ring. Remove and discard the old cartridge valve. Do not discard the $\frac{3}{4}$ " gasket. Replace with a new cartridge valve. Once again, be sure to install the new cartridge valve according to the diagram below. The valve must be positioned the correct way to function properly. Reinstall the $\frac{3}{4}$ " gasket and screw the quick connect insert ring back onto the pump.
7. The hand pump only requires an occasional application of lubrication on the piston shaft and O-ring to keep it in operating condition

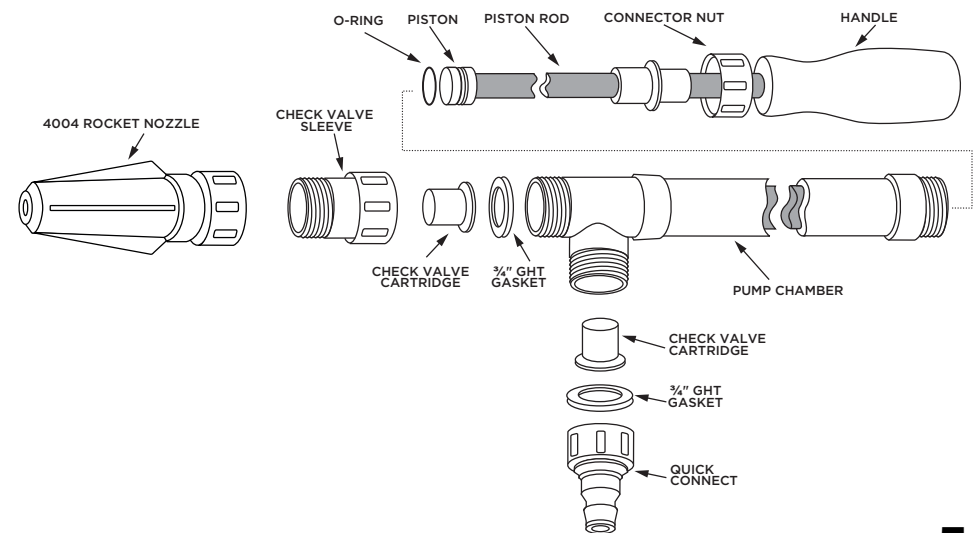

Components & Parts



1 F-PUMPCHMBRASSMYEL **2** F-PISTRODASSMB **3** 4062 **4** 4004-YF
5 F-SLEEVECHKVLVCART **6** 4066 **7** F-STRAPHANDLERRETAIN
8 4000SERV-CC **9** 4063 **10** 4777



11 F-HARNESS4002A **19** F-CONT5GBAGA
12 F-LID4CLOSEDBLK **20** F-FLANGE34NYL
13 S-ORING241D70 **21** F-GSKT34FLANGE
14 F-SCRNRETRNG **22** F-FLANGENUT34
15 F-SCRNFILFLNG4
16 F-FLANGENUT4
17 F-FLANGERING4
18 F-FLANGEFIL4



SCOTTY FIREFIGHTER

2065 Henry Ave West
Sidney, British Columbia
Canada V8L 5Z6

PHONE	250 656 8102
TOLL FREE	1 800 214 0141
FAX	250 656 8126
EMAIL	fire@scotty.com



scottyfire.com

Warranty Information

Scotty Firefighter, a Division of Scotty Manufacturing Ltd. (hereto referred to as "Scotty") warrants the original purchaser of its Scotty Firefighter line of products, (hereto referred to as "equipment") and to anyone to whom it is sold or transferred to, that the equipment shall be free from defects in material and workmanship during the two (2) year period from the date of purchase. Scotty's obligation under this warranty is specifically limited to replacing or repairing the equipment, which are shown, through examination carried out by Scotty personnel or Scotty authorized Distributors, to be in a defective condition attributable to Scotty. To qualify for this limited warranty, the claimant, within a reasonable amount of time after discovery of the defect or issue, must contact Scotty or their Scotty authorized Distributor in writing describing said condition. If required, the claimant will return the equipment to Scotty, or to the original authorized Distributor who will return to Scotty. Scotty will inspect the equipment and if Scotty determines that there is a defect attributable to material and workmanship, Scotty will replace or repair the equipment under warranty. Scotty shall have no obligation under this limited warranty if the equipment is, or has been misused or neglected (including failure to provide reasonable maintenance) or if there have been accidents to the equipment or it has been repaired or altered by someone else.